

### This Reference Document:

This document provides information from certification E01662-LRC3 for the direct restraint of Access Equipment for HRIA and its members. This also extends to member customers and subcontractors. Alternative load restraint systems or methods may be used provided they are supported by testing or engineering advice that demonstrates compliance with the loading performance standards specified in schedule 7 of the Heavy Vehicle (Mass, Dimension and Loading) National Regulation (as published 1/10/2018).

Documentation applies to :

- Access Equipment:
  - Boom Lifts
  - Scissor Lifts
  - Vertical Mast Lifts
  - Telehandlers
- Access Equipment with a mass no greater than 21.1t
- Access Equipment with a width no greater than 2450mm
- Access Equipment in serviceable condition and no major defects
- Access Equipment transported on tilt trays and heavy haulage trailers
- Unitised contained accessories for nominated Access Equipment that form the same transport movement

**BOOM LIFT**

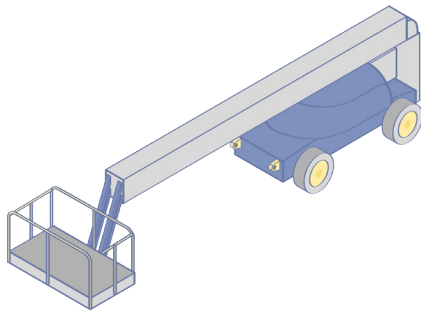

**SCISSOR LIFT**

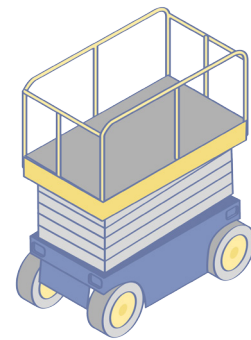

**VERTICAL MAST LIFT**

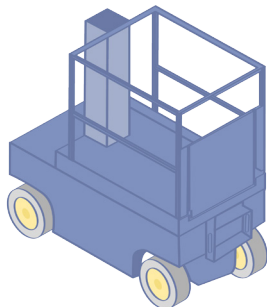

**TELEHANDLER**

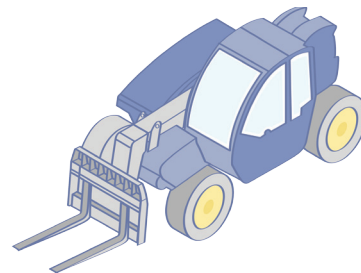

This documents information has been certified (E01662 - LRC3) to comply with the HVNL loading performance standards contained in Schedule 7 of the Heavy Vehicle (Mass, Dimension and Loading) National Regulation (as published 1/10/2018) for HRIA (Hire and Rental Association). Certification provided by RPEQ, CPEng 3121238. Compliance can only be achieved when all aspects of this document are adhered to in full. Additional requirements may be necessary under some conditions that are outside the scope of this certification. The information contained in this certification is confidential to and remains the property of HRIA and Engistics. Any changes to this certification must be approved by Engistics.

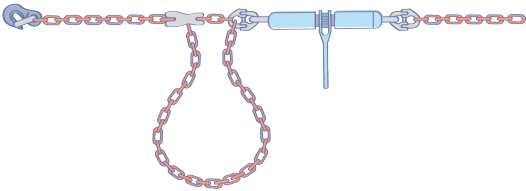
Section A Requirements	Category	Page
	1. Load Restraint Equipment	3
	2. Key Considerations	4 - 5

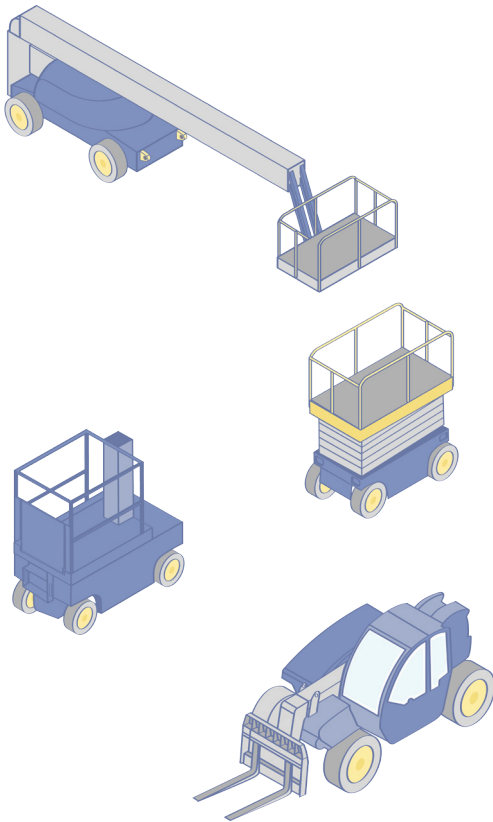
Section B Earth Moving Restraint	Category	Page
	1. Up to 3.8t	6
	2. Between 3.8t - 5.5t	7
	3. Between 5.5t - 7.5t	8
	4. Between 7.5t - 12.2t	9
	5. Between 7.5t - 12.7t	10
	6. Between 12.2t - 21.1t	11

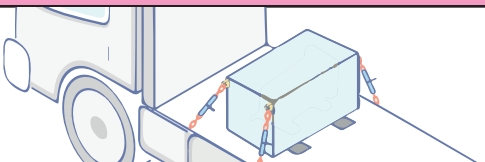
Section C Accessories	Category	Page
	1. General	12
	2. Required Lashings	12

### Load Restraint Equipment

All equipment must conform to AS/NZ 4344 and AS/NZS4380 standards with consideration taken for the following:

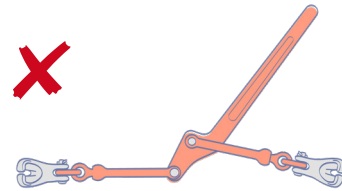
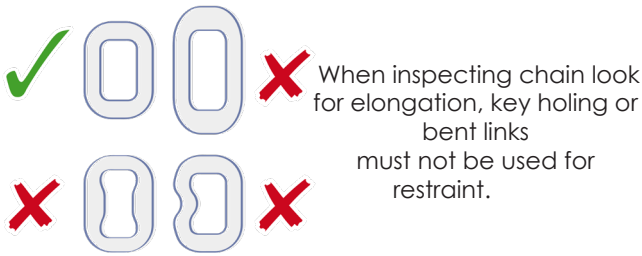

Do No use over-center lever load binders (Dogs)

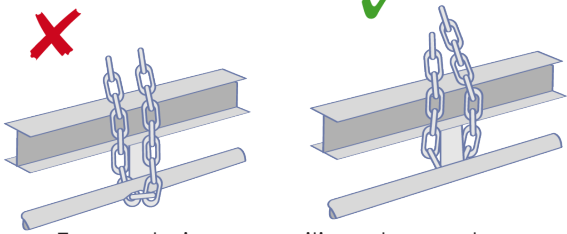

Ensure chains are positioned around load post.



Torn or excessively worn webbing straps must not be used for restraint.

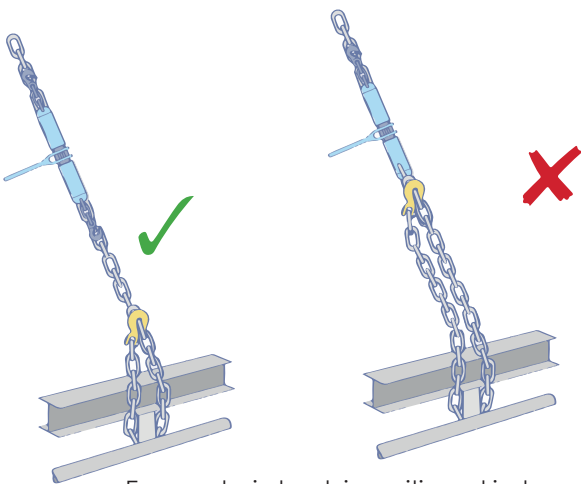

Ensure chain hook is positioned just above the coaming rail.

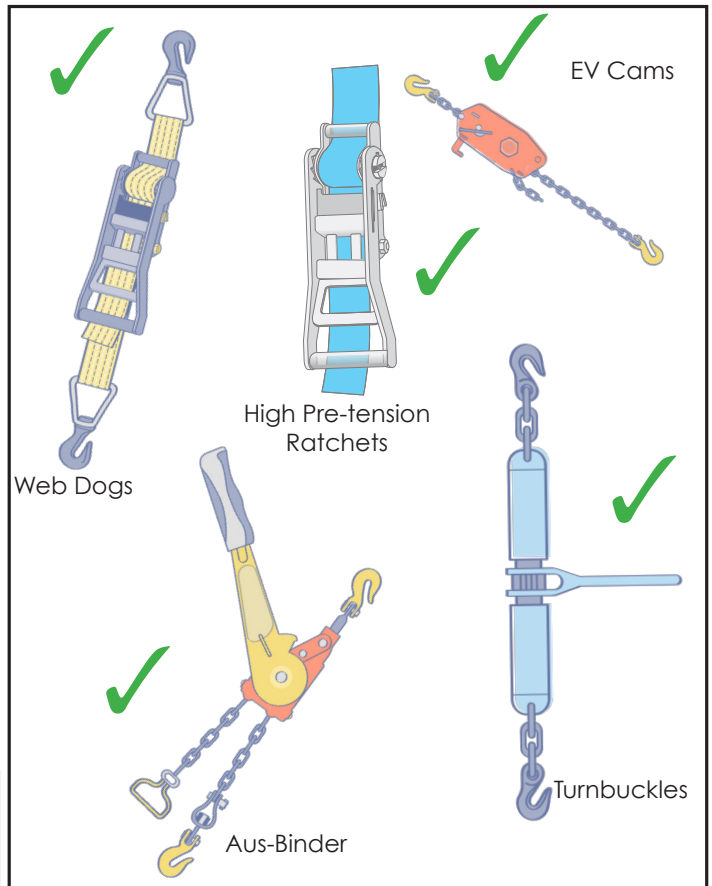

Use appropriate ratchets conforming to AS/NZS4380

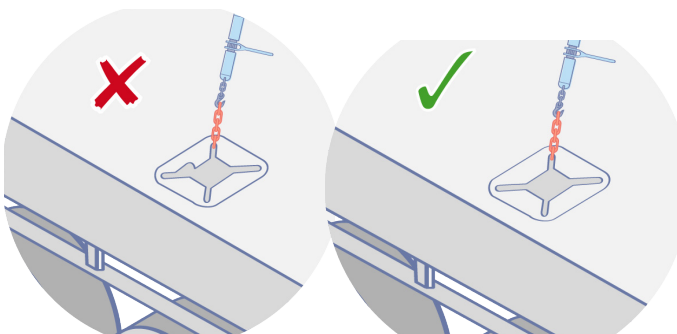

Do No use damaged anchor points. Ensure their capacity is suitable for transport task.

### Key Considerations

- ✓ A minimum of four lashings will be required, two angled forwards and two backwards.
- ✓ All lashings to be similar geometry.
- ✓ Apply any brakes provided as per mobile plant operators manual
- ✓ All on board equipment must be secured in the operators cabin or designated compartment.
- ✓ All hydraulic and mechanical equipment must be isolated, as per operators manual, to prevent inadvertent movement in transit.
- ✗ Do not use webbing straps for restraint of access equipment. (Note: Webbing straps may be used to restrain booms and baskets as per operators manual).

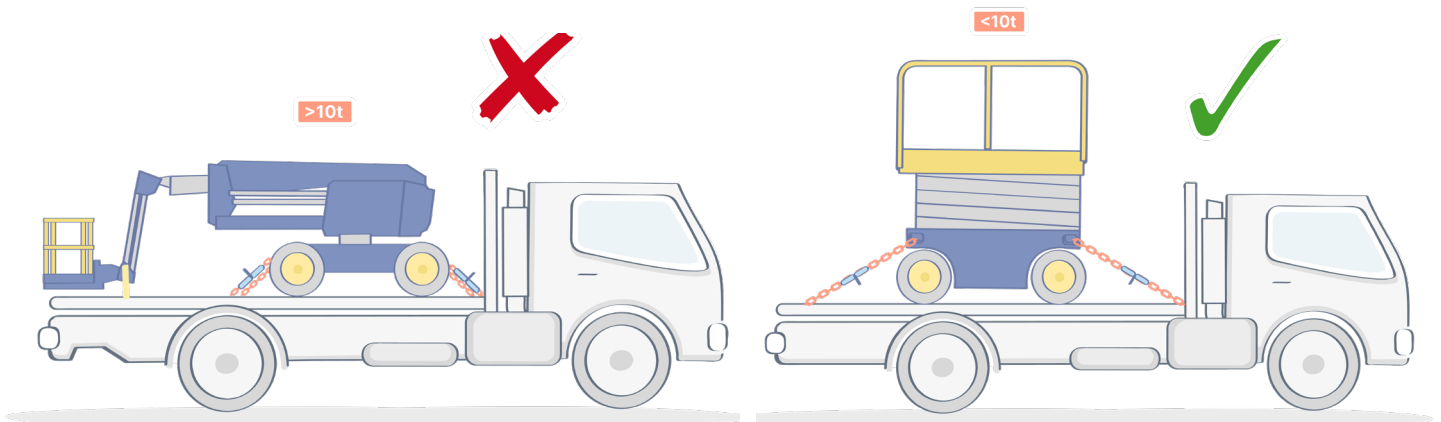
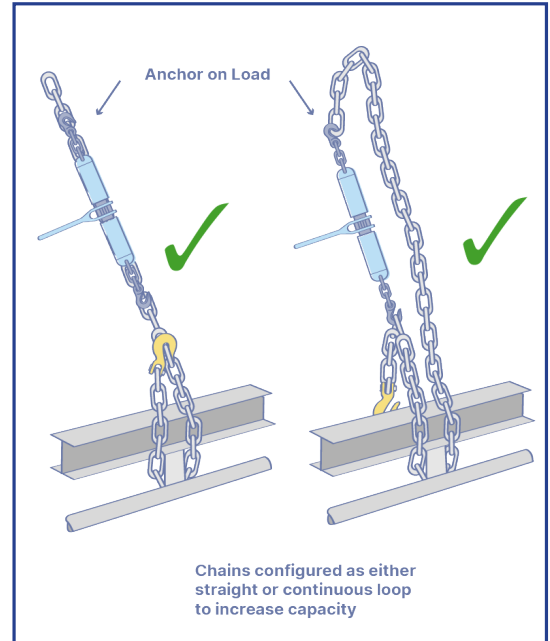

Keep loads on tilt trays and rigid vehicles to under 10t. To ensure anchor points restraint capacities are not exceeded.

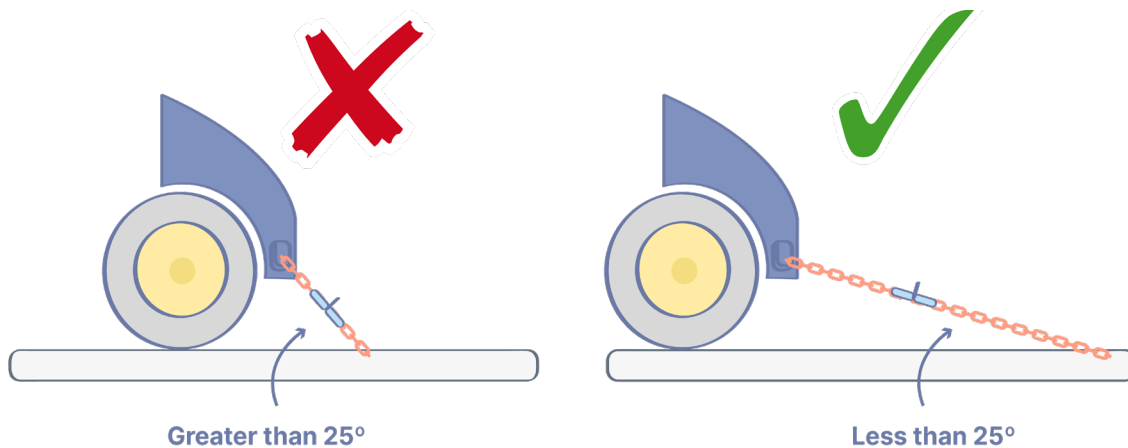

Keep lashing angles to 25° or less to increase restraint effectiveness and minimise shock load to the chain.

### Key Considerations

- ✓ Ensure booms and baskets are secured as per operators manual.
- ✓ Ensure turntable or slewing arm lockout pin is engaged and free of dirt.
- ✓ Latch basket gates and cabin doors prior to transport. Secure doors and gates with faulty latches.
- ✓ Ensure all pipe cradles and tool boxes are attached in baskets or secured as per accessories.
- ⚠ Beware of damaging hydraulic hoses, pneumatic hoses and electrical cable when securing booms and baskets.

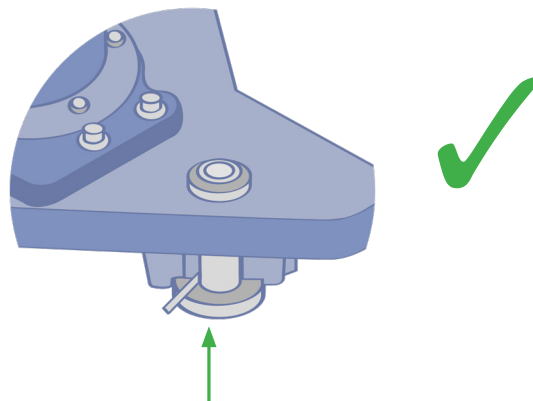

Lockout slewing arm by engaging locking pin prior to transport. Ensure it is free of dirt and mud prior to locking

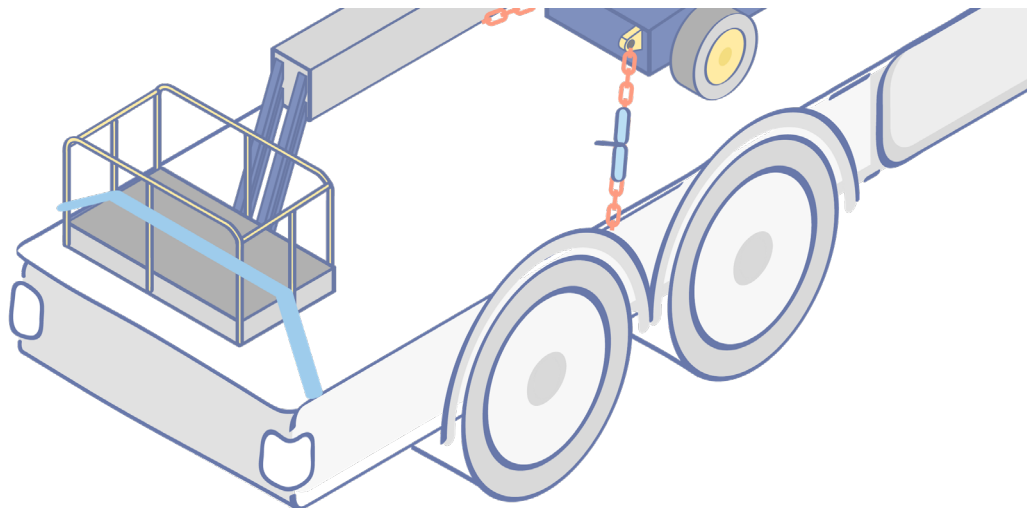

Tie down baskets and booms for transport as per operators manual

### Access Equipment Load Restraint up to 3.8t

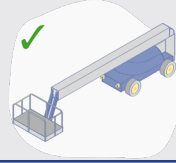

Wheeled, unblocked, minimum of 4 x 8 mm straight chains

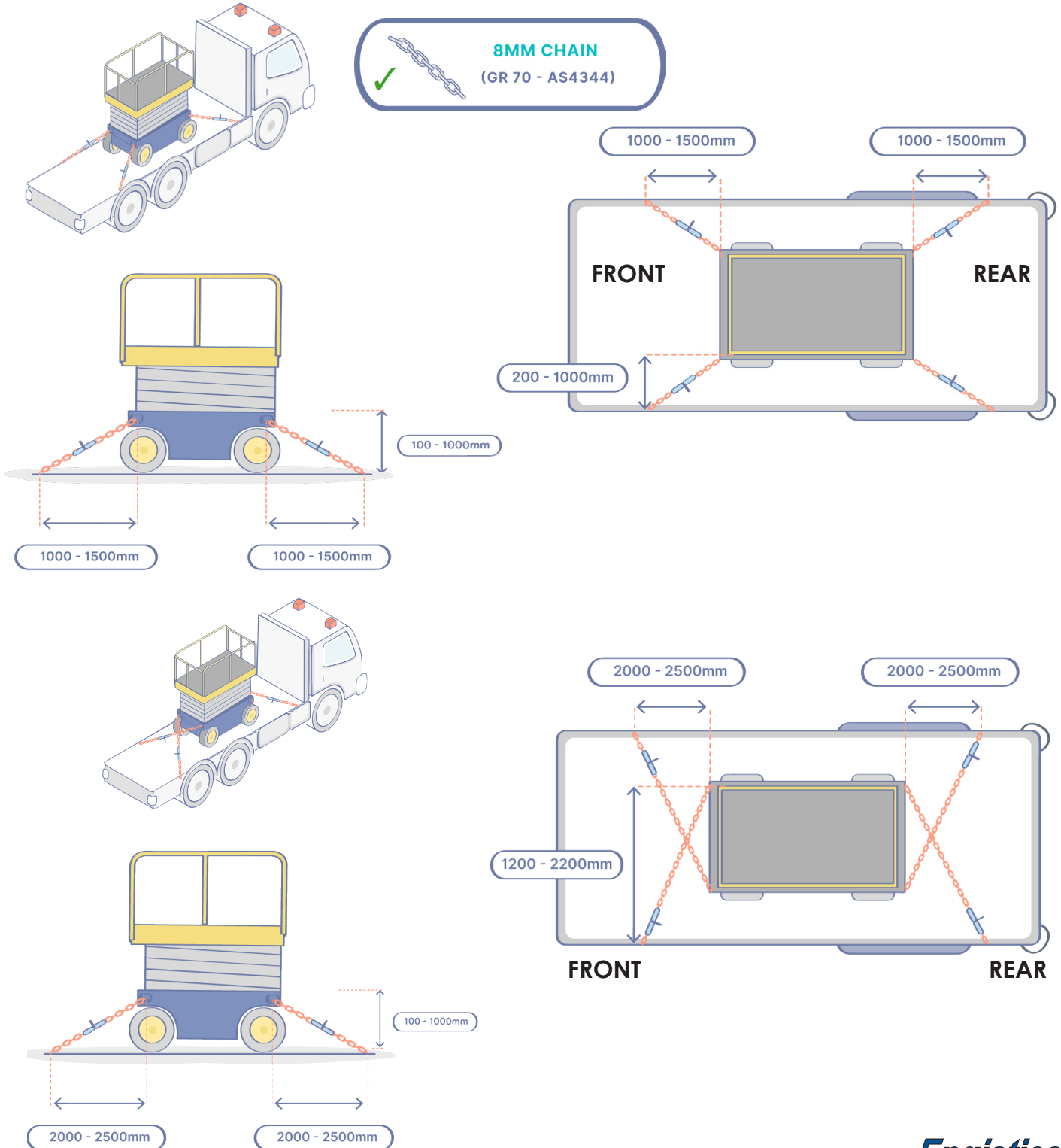

### Access Equipment Load Restraint between 3.8t - 5.5t

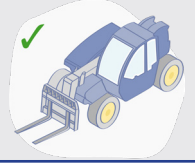
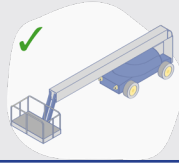

Wheeled, unblocked, minimum of 4 x 10 mm straight chains

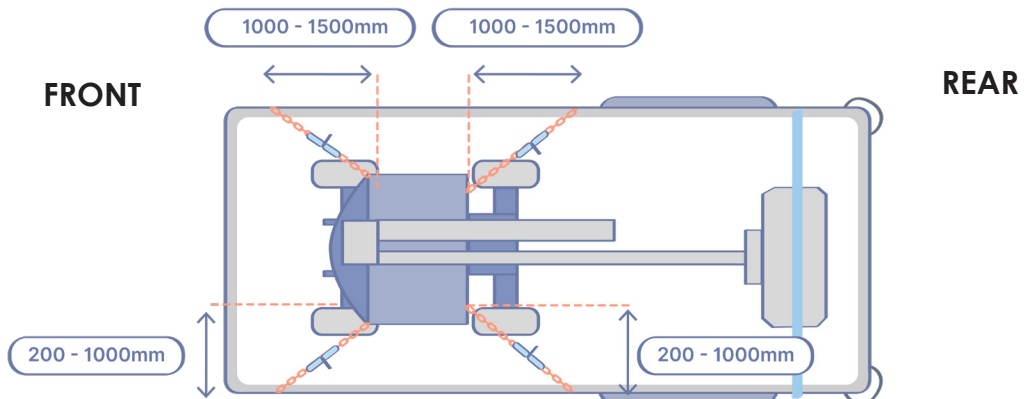
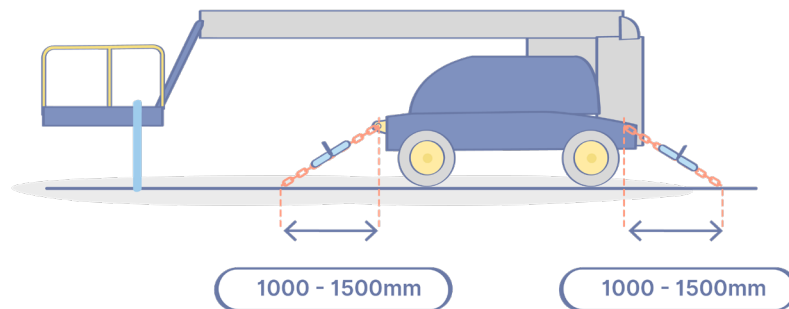
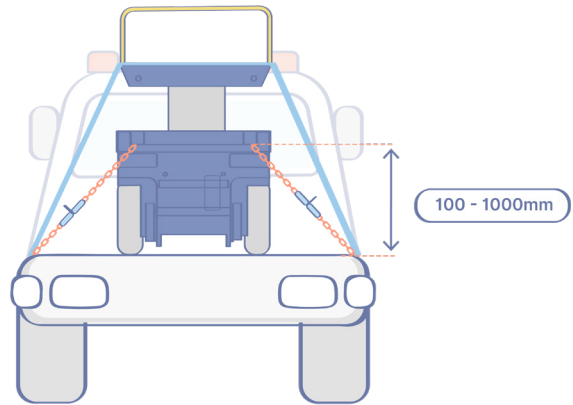
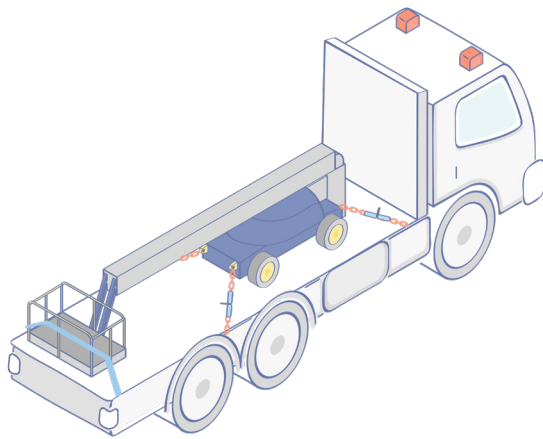

### Access Equipment Load Restraint between 5.5t - 7.5t

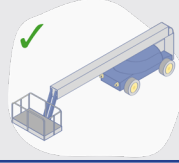

Wheeled, unblocked, minimum of 4 x 8 mm looped chains

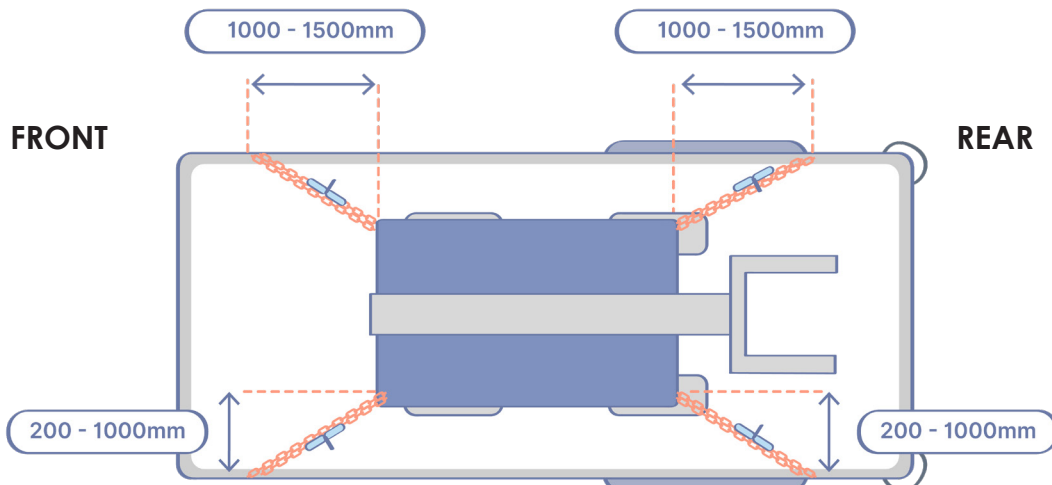
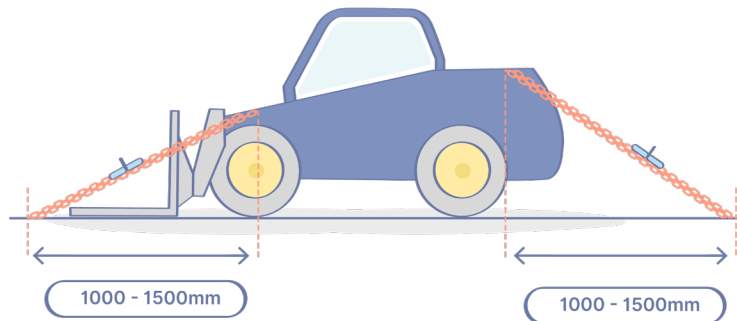
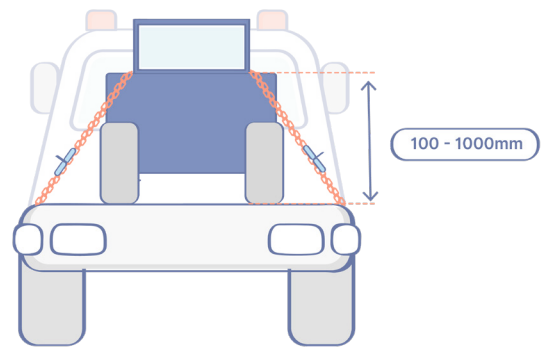
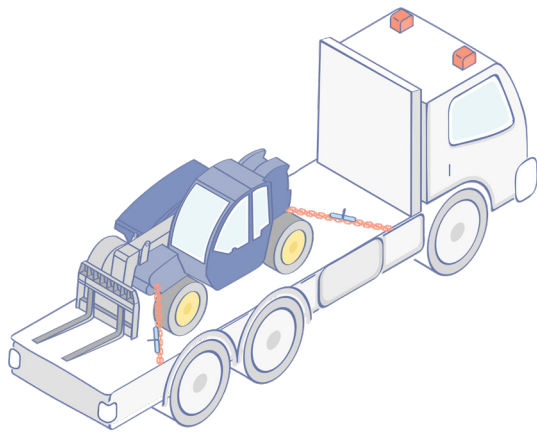

### Access Equipment Load Restraint between 7.5t - 12.2t

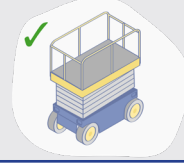
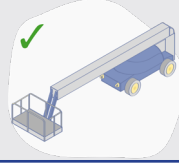

Wheeled, unblocked, minimum of 4 x 10 mm looped chains

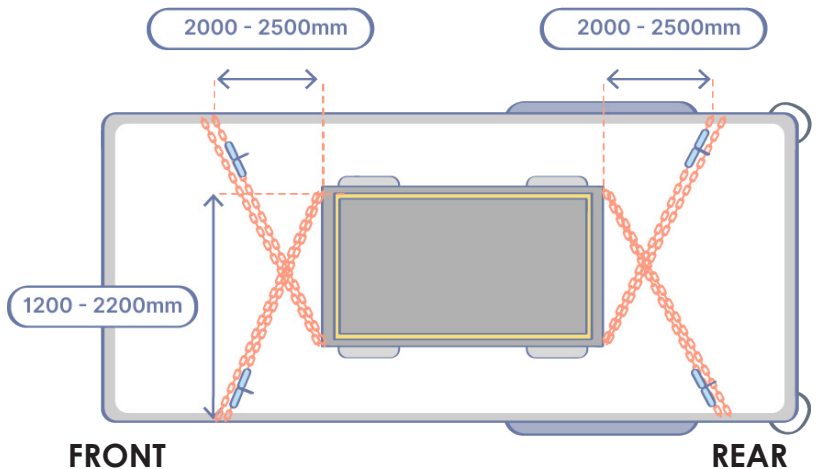
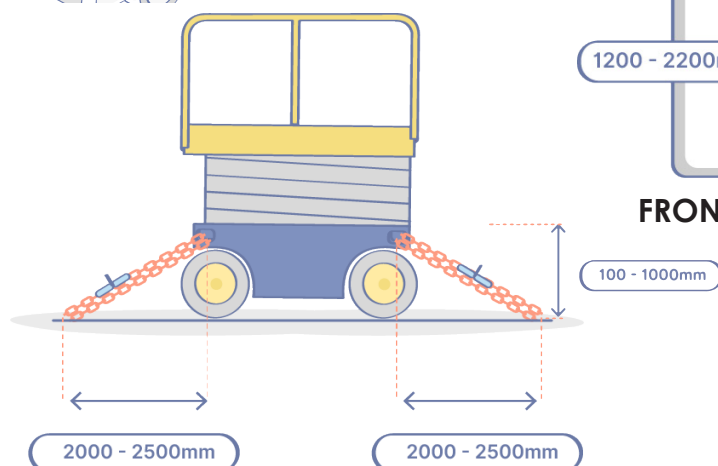
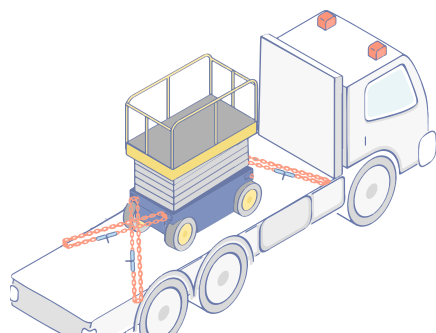
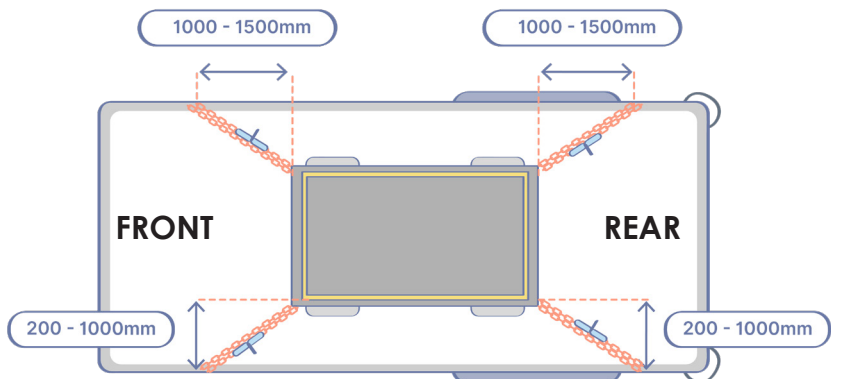
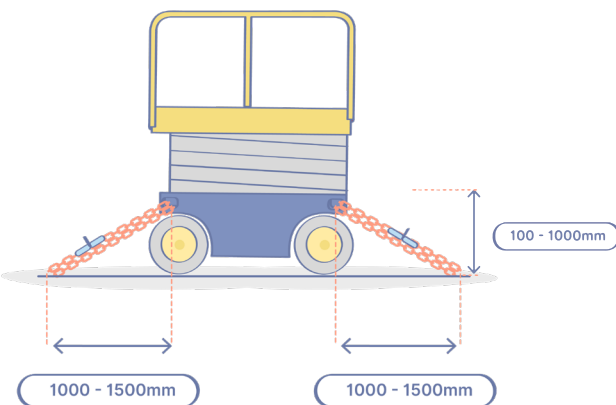
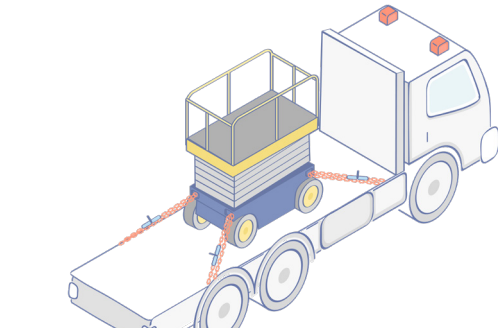

### Access Equipment Load Restraint between 7.5t - 12.7t

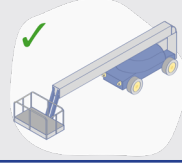

Wheeled, unblocked, minimum of 6 x 8 mm looped chains

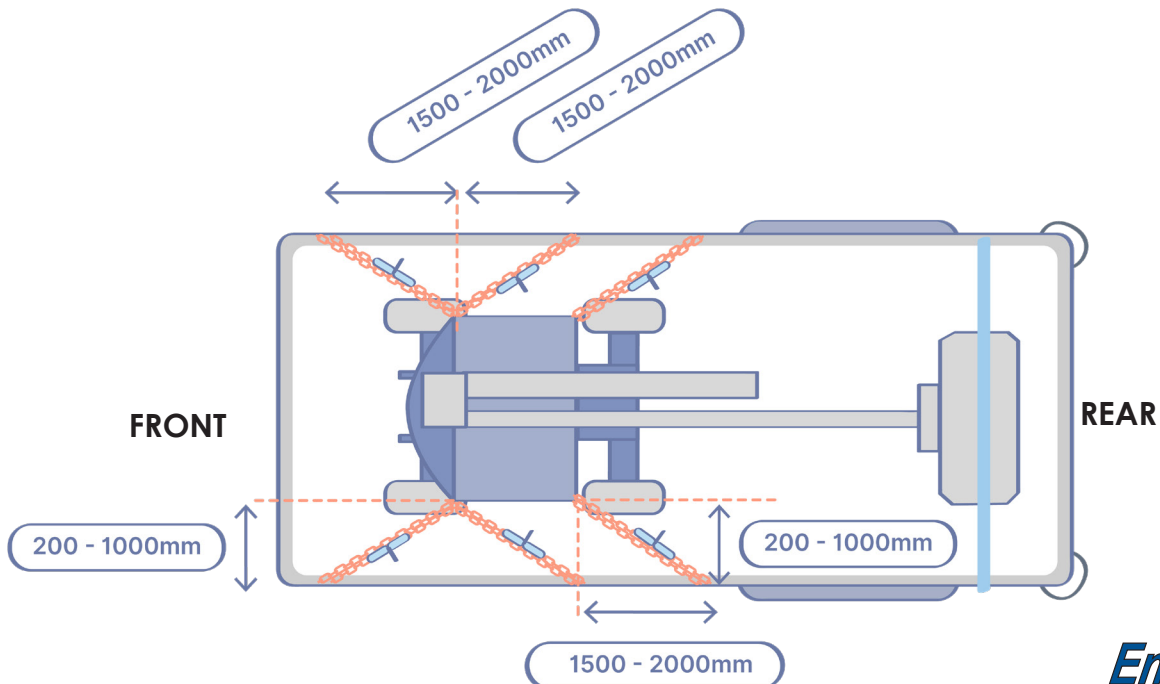
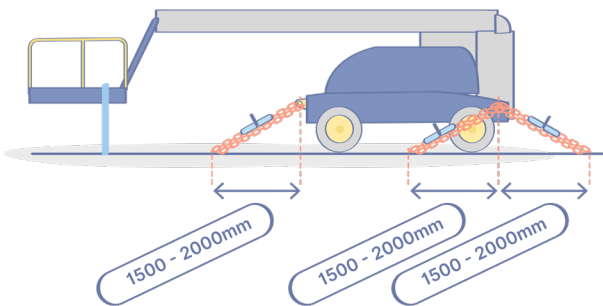
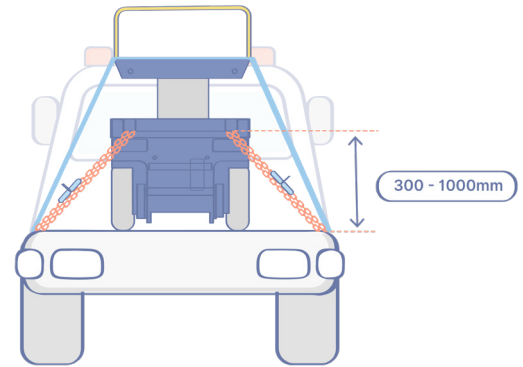
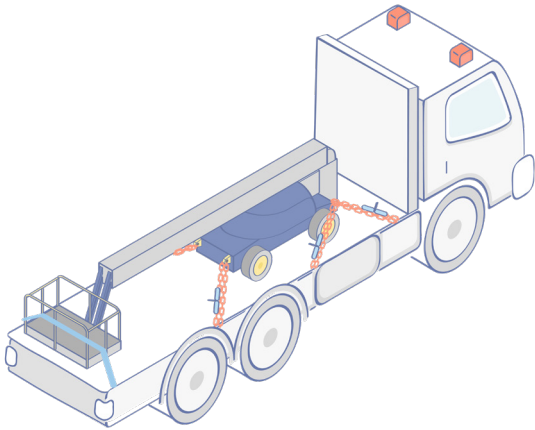

### Access Equipment Load Restraint between 12.2t - 21.1t

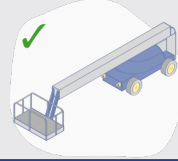

Wheeled, unblocked, minimum of 6 x 10 mm looped chains

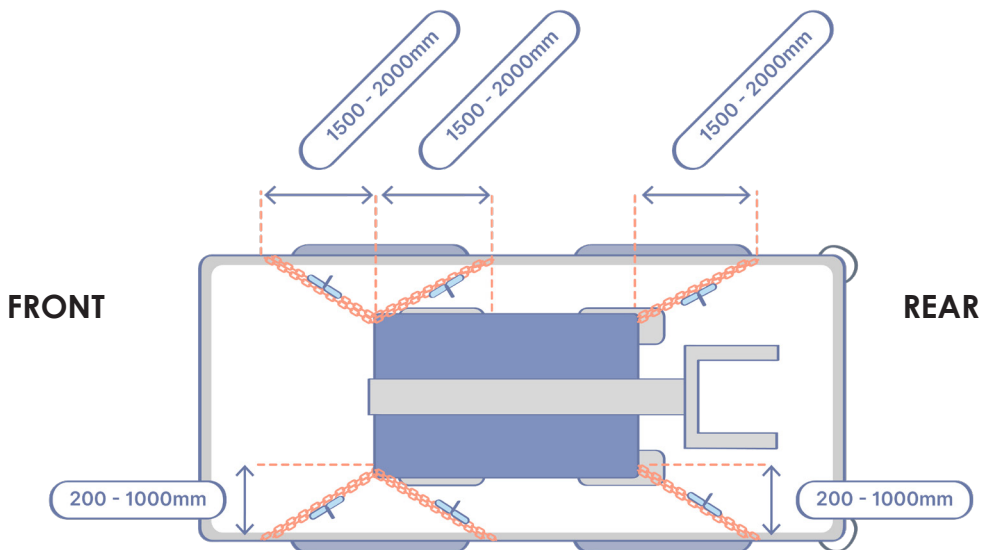
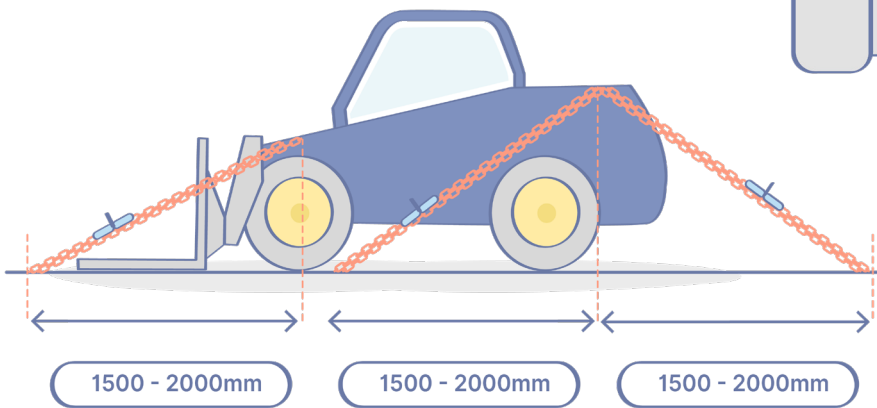
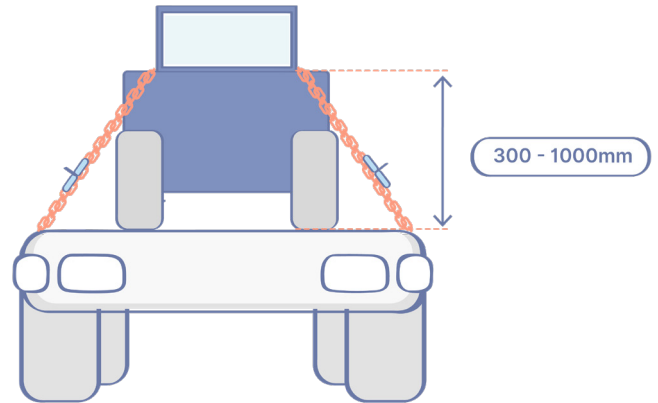
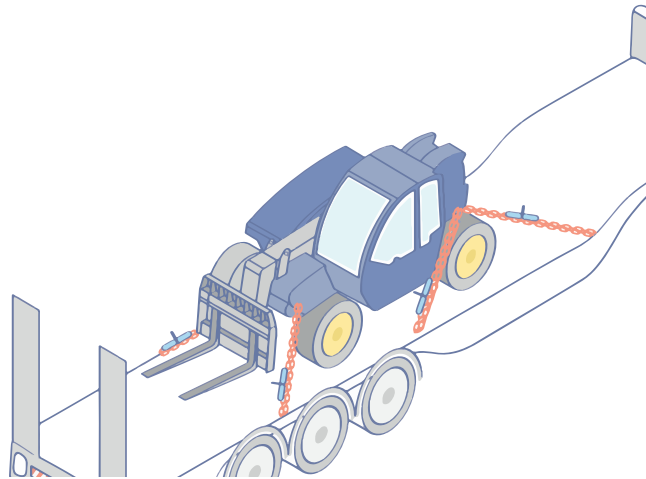

### Accessories

#### General

- ✓ When securing accessories independent of plant ensure the correct size and quantities of chain are used for the given weight. (see table below)
- ✓ Ensure there are no loose items left on the deck. Loose items can be secured singularly, in designated storage compartments or packed in a rated stillage or storage box.
- ⚠ Steel on steel contact reduces friction. Where possible use anti-slip, industrial rubber or timber to increase surface friction.

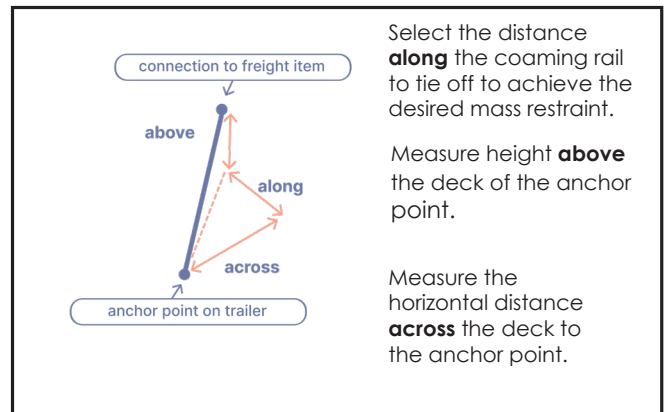
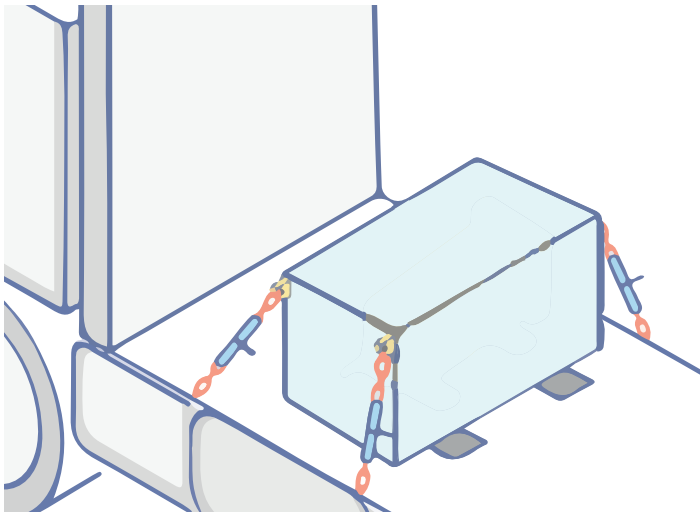

#### Engineered Maximum Permissible Restrained Mass

**Direct Restraint Table - 4 lashings placed on timber or industrial rubber frictional coefficient 0.4**

	Anchor Point Across Deck (mm)	Location Along Coaming Rail for Lashing (mm)	Mass per 4 x 50mm Webbing	Mass per 4 x 8mm Chain
 Height of Anchor Point (mm) 300 - 599	250 - 499	0 - 249	900 kg	3000 kg
		250 - 500	1500 kg	5000 kg
	500 - 750	0 - 249	617 kg	2000 kg
		250 - 500	1100 kg	3500 kg
Height of Anchor Point (mm) 599 - 1000	250 - 499	0 - 249	1100 kg	3500 kg
		250 - 500	1500 kg	5000 kg
	500 - 750	0 - 249	900 kg	3000 kg
		250 - 500	1300 kg	4000 kg