

This Reference Document:

This document provides information from certification E01662-LRC2 for the direct restraint of Compaction Equipment for HRIA and its members. This also extends to member customers and subcontractors. Alternative load restraint systems or methods may be used provided they are supported by testing or engineering advice that demonstrates compliance with the loading performance standards specified in schedule 7 of the Heavy Vehicle (Mass, Dimension and Loading) National Regulation (as published 1/10/2018).

Documentation applies to :

- Compaction Equipment:
 - Tandem Drum Roller (Smooth or Padfoot drum)
 - Single Drum Roller (Smooth or Padfoot drum)
 - Pneumatic Roller
 - Trench Roller (Smooth or Padfoot drum)
- Compaction Equipment with a mass no greater than 21t
- Compaction Equipment with a width no greater than 2450mm
- Compaction Equipment in serviceable condition and no major defects
- Compaction Equipment transported on tilt trays and heavy haulage trailers
- Accessories for nominated Compaction Equipment that form the same transport movement

TANDEM DRUM ROLLER

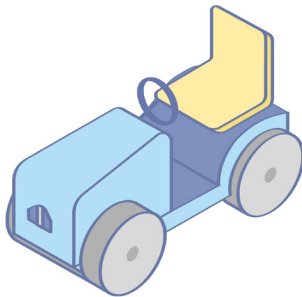

SINGLE DRUM ROLLER

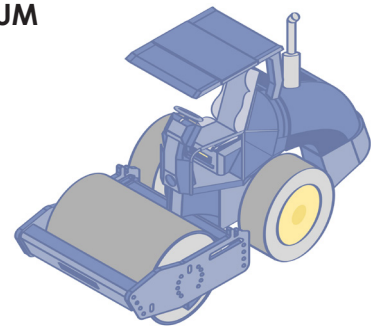

PNEUMATIC ROLLER

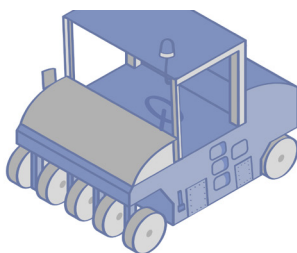

TRENCH ROLLER

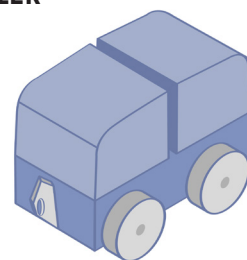

This documents information has been certified (E01622 - LRC2) to comply with the HVNL loading performance standards contained in Schedule 7 of the Heavy Vehicle (Mass, Dimension and Loading) National Regulation (as published 1/10/2018) for HRIA (Hire and Rental Association). Certification provided by RPEQ, CPEng 3121238. Compliance can only be achieved when all aspects of this document are adhered to in full. Additional requirements may be necessary under some conditions that are outside the scope of this certification. The information contained in this certification is confidential to and remains the property of HRIA and Engistics. Any changes to this certification must be approved by Engistics.

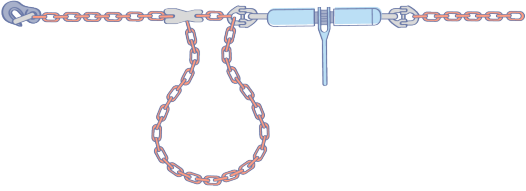
Section A Requirements	Category	Page
	1. Load Restraint Equipment	3
	2. Key Considerations	4

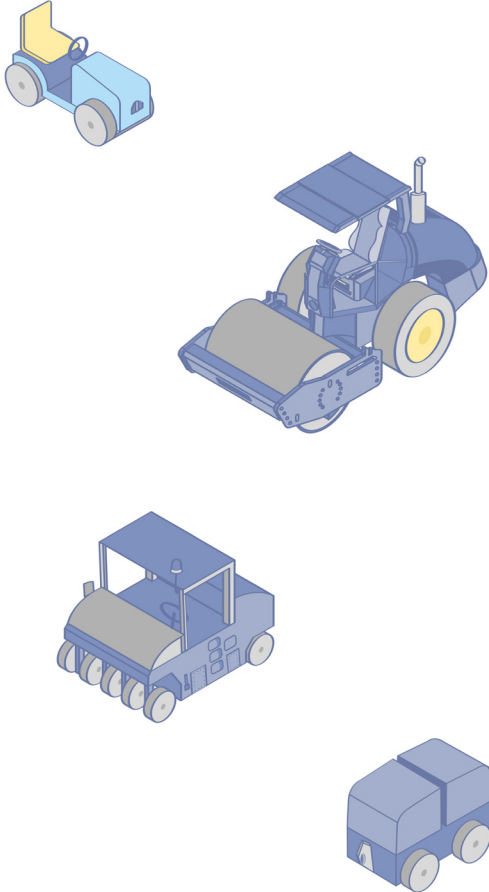
Section B Compaction Equipment Restraint	Category	Page
	1. Up to 1.6t	5
	2. Between 1.6t - 3.5t	6
	3. Between 3.5t - 8t	7
	4. Between 3.5t - 10t	7
	5. Between 10t - 13.5t	8
	6. Between 13.5t - 21t	9

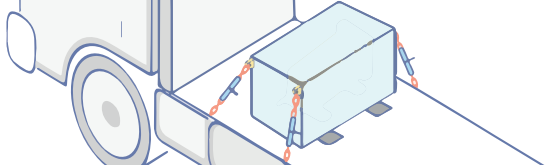
Section C Accessories	Category	Page
	1. General	10

Load Restraint Equipment

All equipment must conform to AS/NZ 4344 and AS/NZS4380 standards with consideration taken for the following:

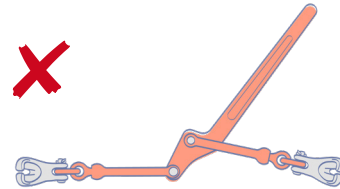
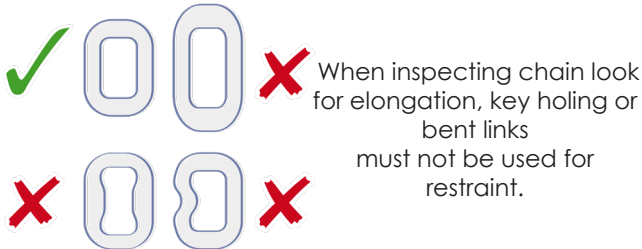

Do No use over-center lever load binders (Dogs)

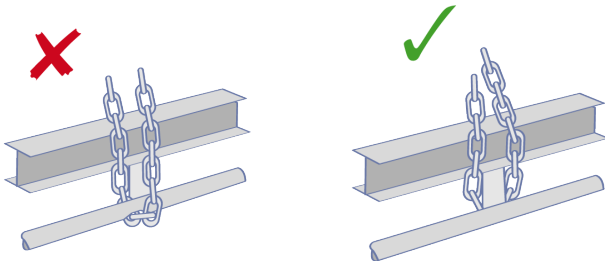

Ensure chains are positioned around load post.

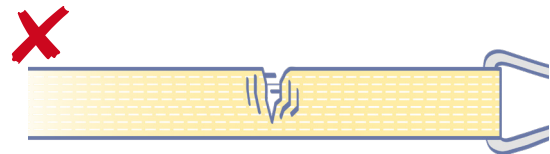

Torn or excessively worn webbing straps must not be used for restraint.

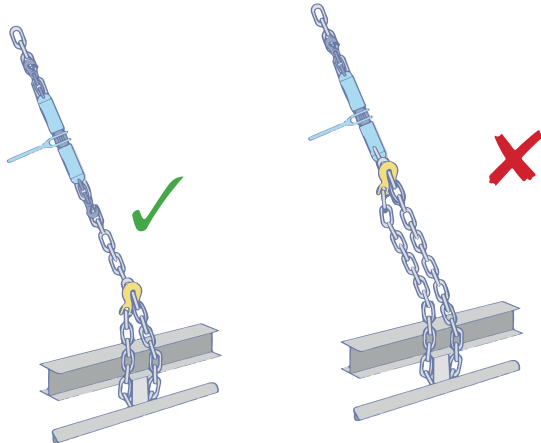

Ensure chain hook is positioned just above the coaming rail.

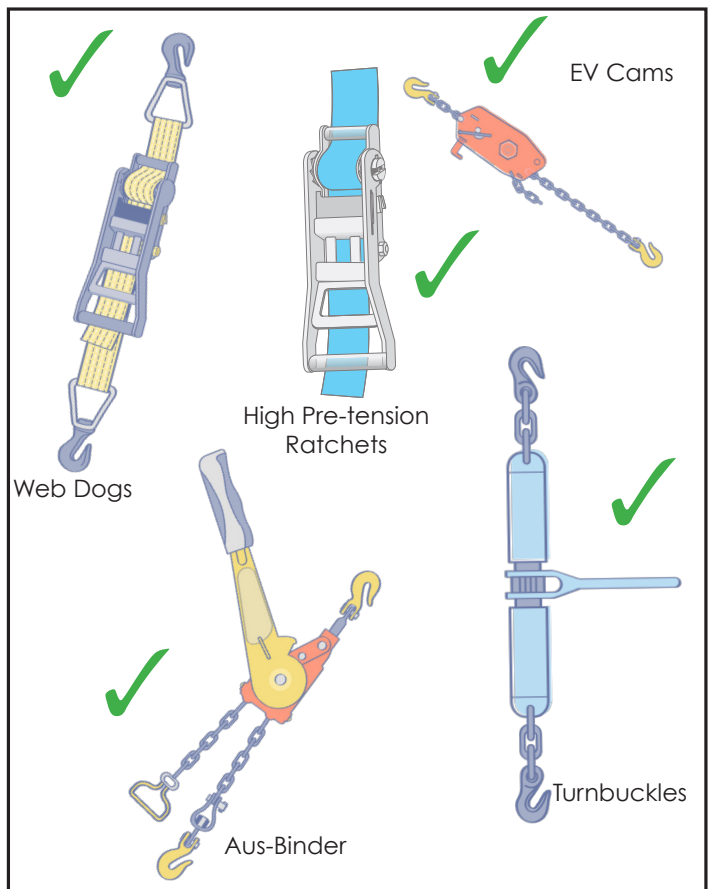

Use appropriate ratchets conforming to AS/NZS4380

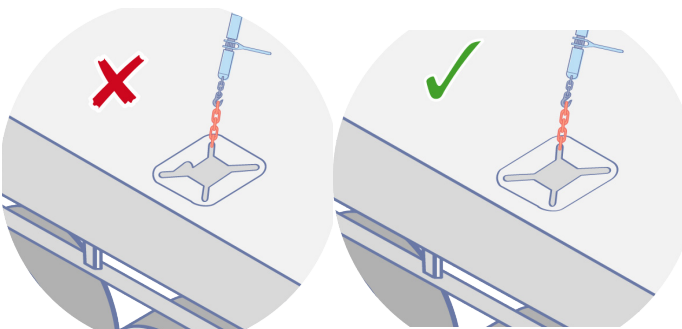

Do No use damaged anchor points. Ensure their capacity is suitable for transport task.

Key Considerations

- ✓ A minimum of four lashings will be required, two angled forwards and two backwards.
- ✓ All lashings to be similar geometry.
- ✓ Apply any brakes provided as per mobile plant operators manual
- ✓ All on board equipment must be secured (e.g. booms and buckets) as per mobile plant operators manual.
- ✓ All hydraulic and mechanical equipment must be isolated, as per operators manual, to prevent inadvertent movement in transit.
- ✗ Do not mix lashing types i.e. chain and webbing on the same item for restraint. (Note: Webbing straps can be used to restrain equipment accessories e.g. Buckets and Baskets).

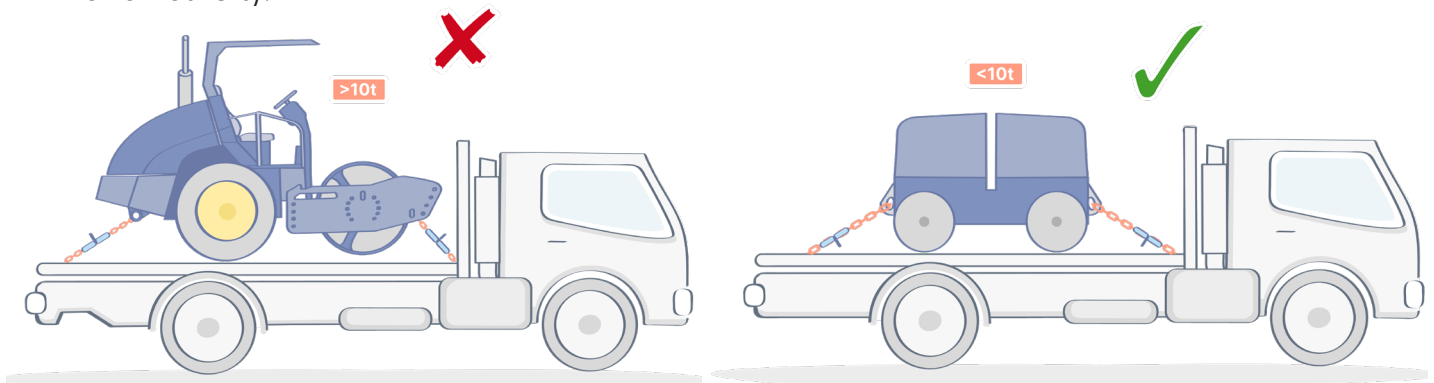
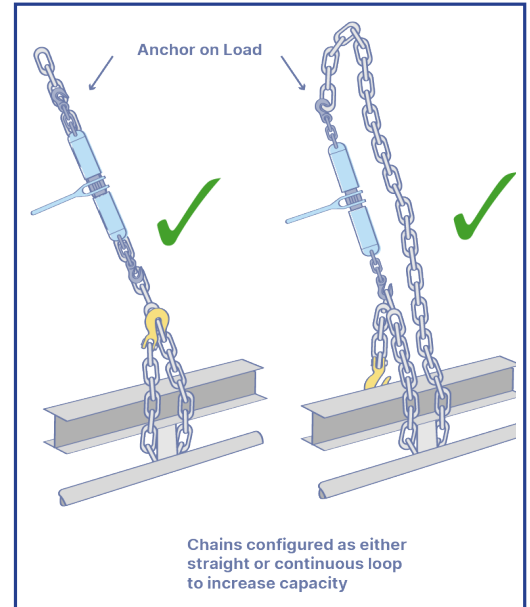

Keep loads on tilt trays and rigid vehicles to under 10t. To ensure anchor points restraint capacities are not exceeded.

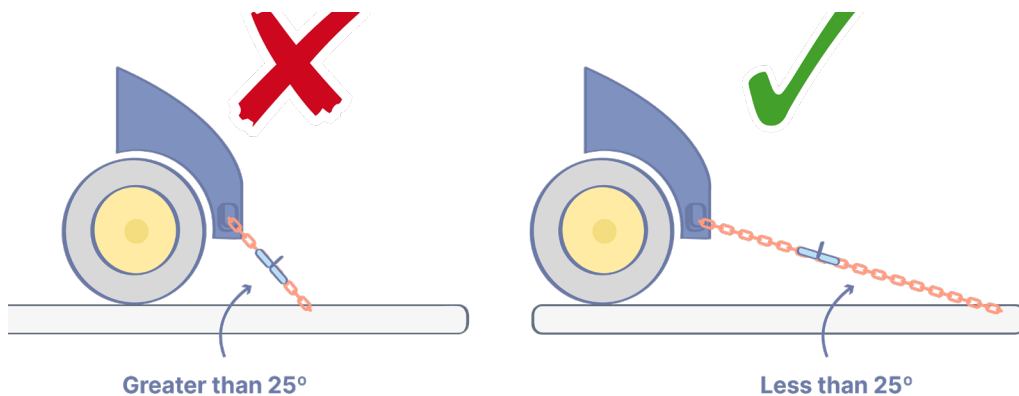

Keep lashing angles to 25° or less to increase restraint effectiveness and minimise shock load to the chain.

Compaction Equipment Load Restraint up to 1.6t



Smooth or Padfoot drum, unblocked, minimum of 4 x 8mm straight chains

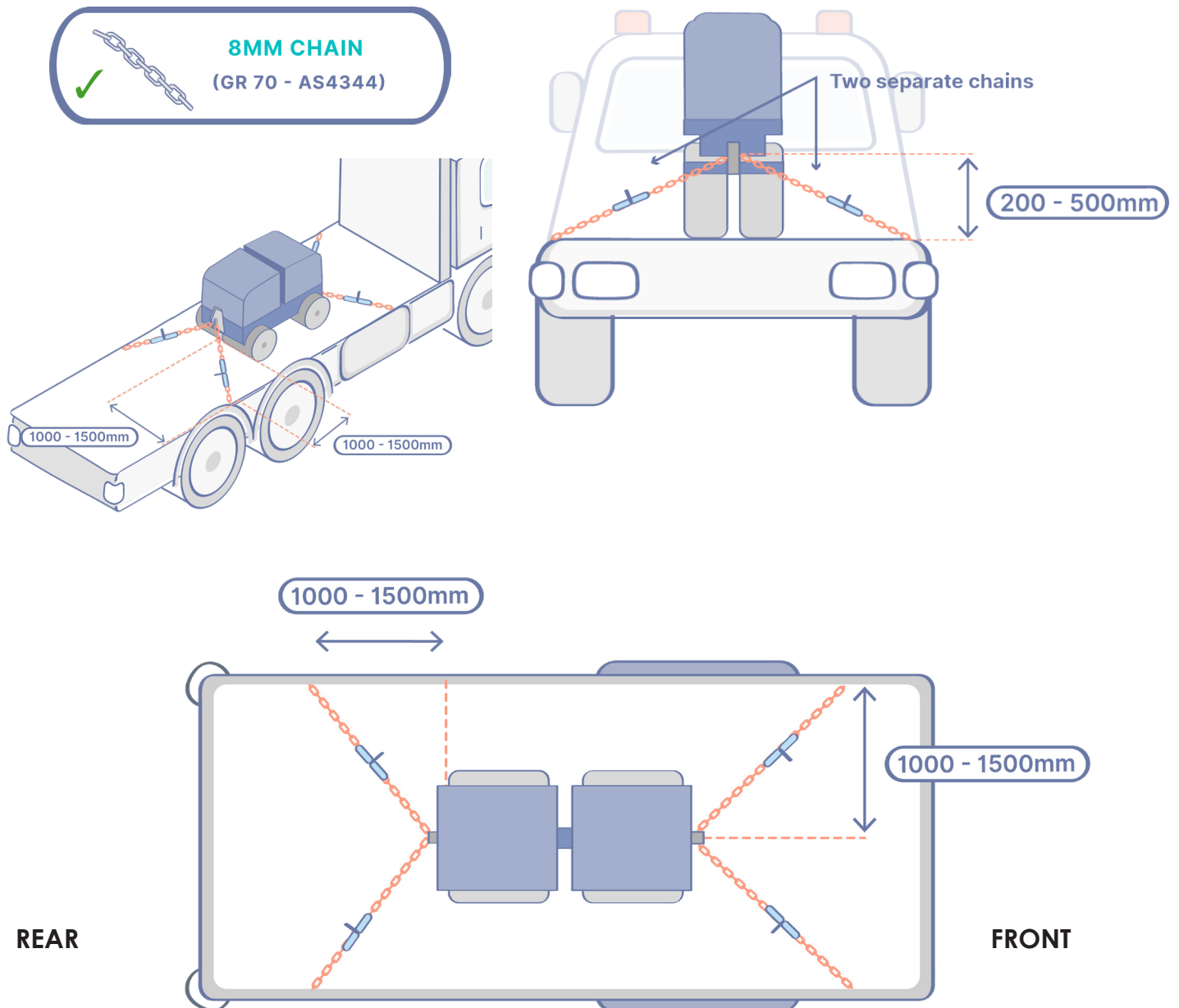

Ensure 4 chains are used, two at either end of the trench roller. Single continuous chain through anchor point is likely to promote sideways movement.

Compaction Equipment Load Restraint between 1.2t - 3.5t



Smooth or Padfoot drum, unblocked, minimum of 4 x 8mm straight chains

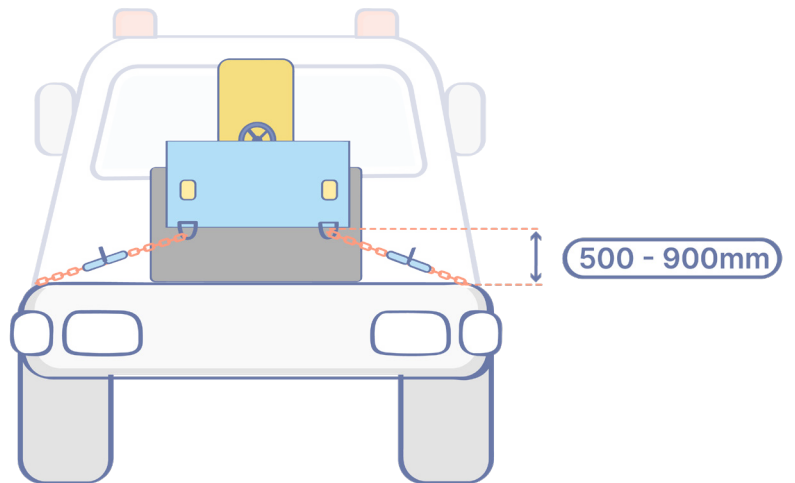
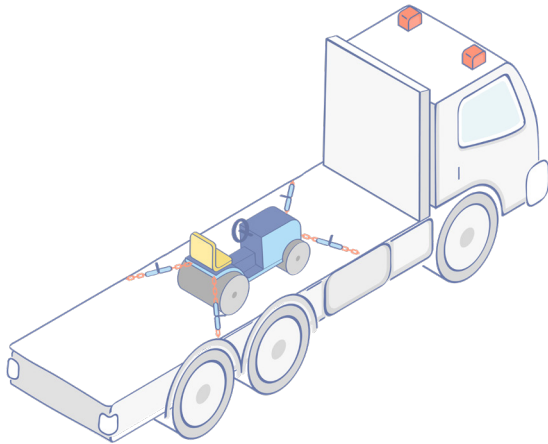

FRONT

REAR

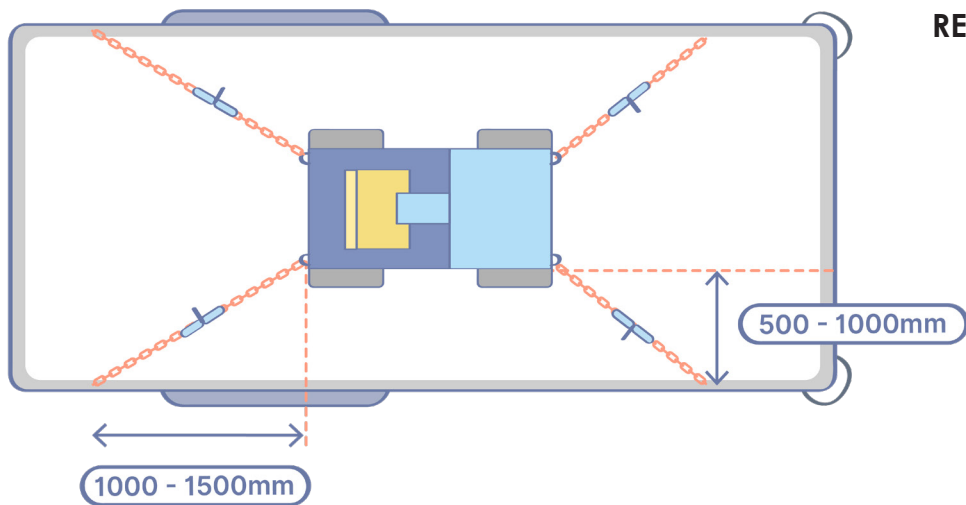

Compaction Equipment Load Restraint between 3.5t - 8t

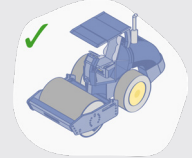

Smooth or Padfoot drum, unblocked, minimum of 4 x 8mm looped chains

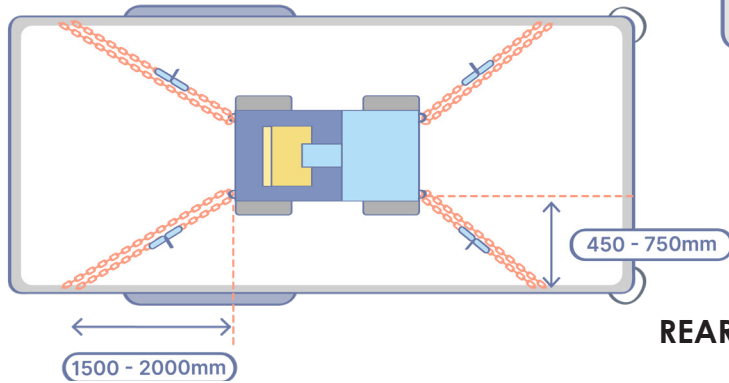
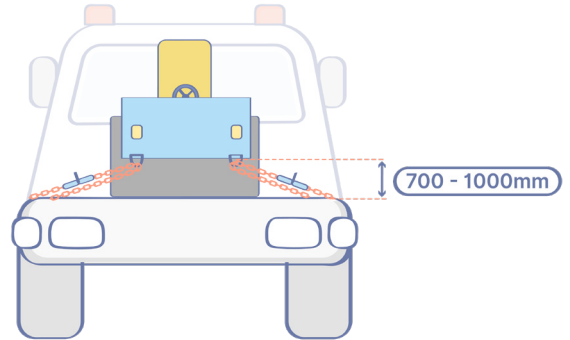
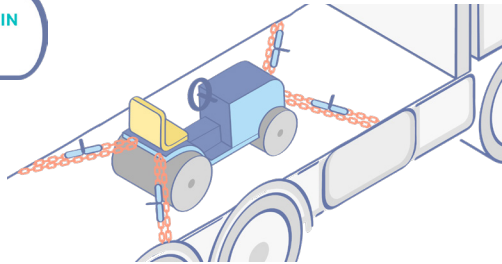

Compaction Equipment Load Restraint between 3.5t - 10t

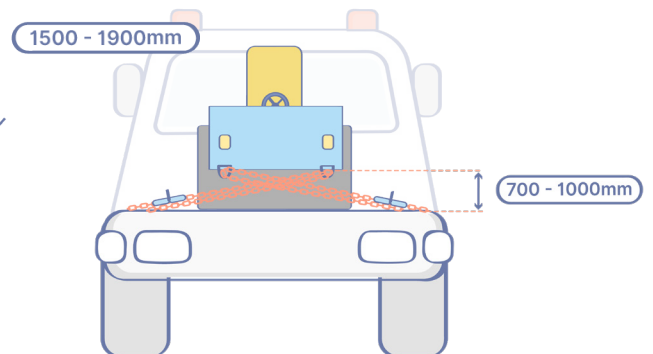
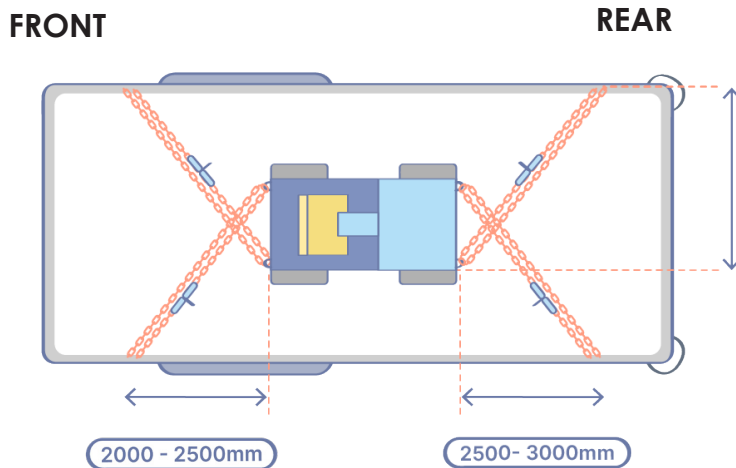
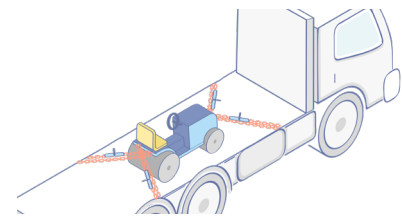

Compaction Equipment Load Restraint between 10t - 13.5t

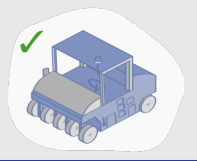

Smooth or Padfoot drum, unblocked, minimum of 4 x 10mm looped chain

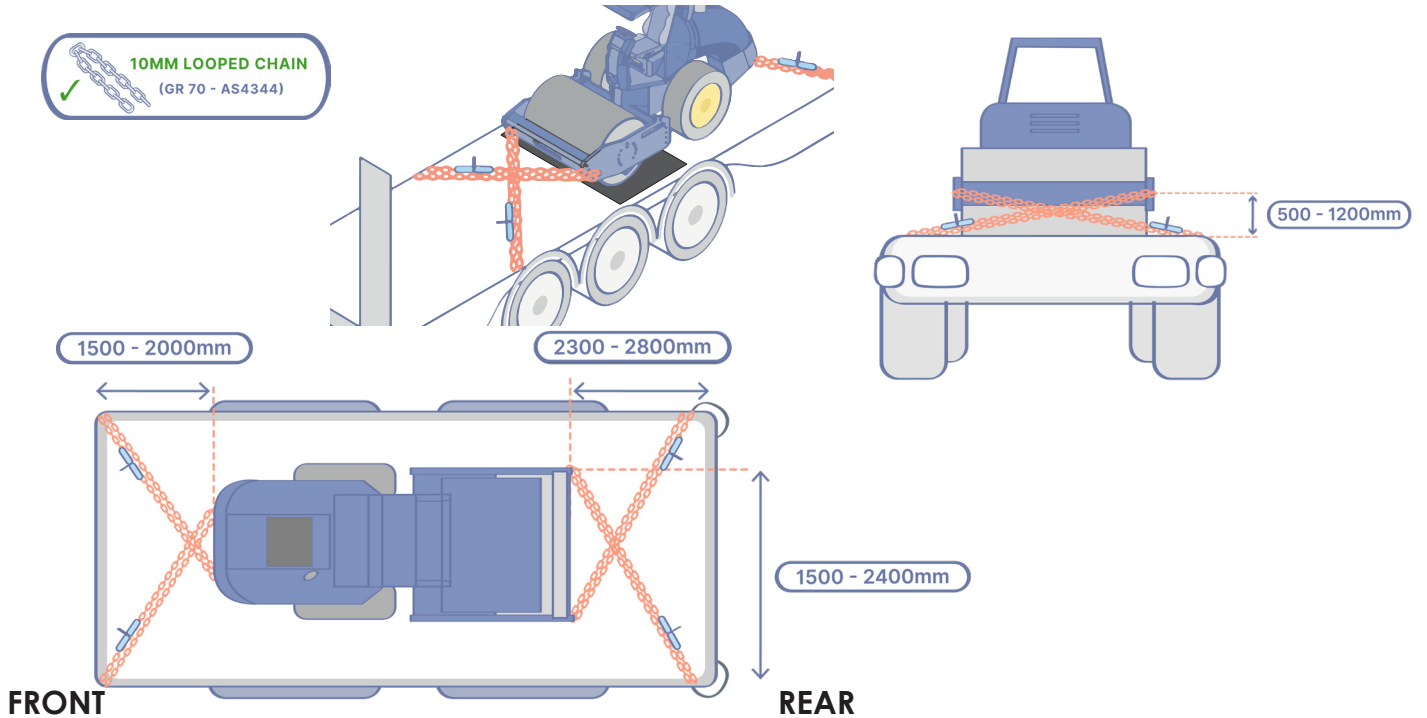

Pneumatic Roller, unblocked, minimum of 4 x 10mm looped chain

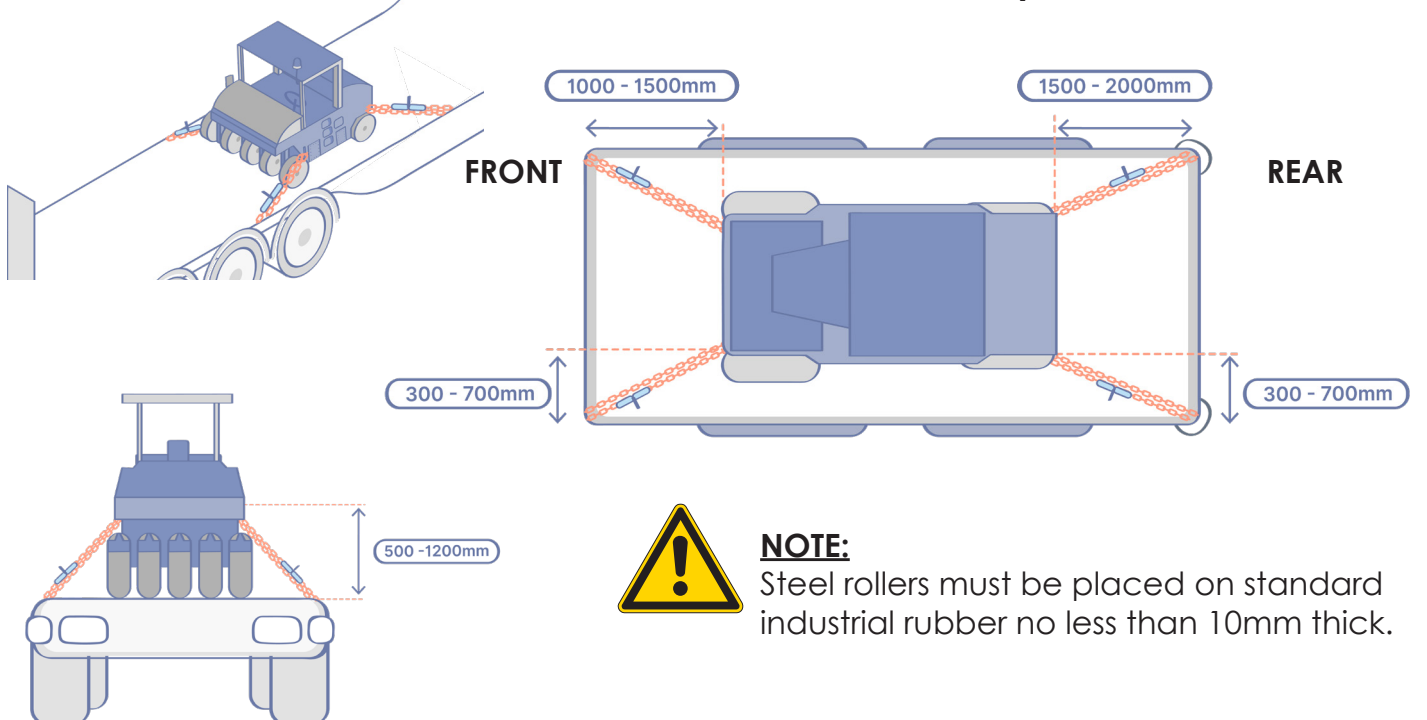

Compaction Equipment Load Restraint between 13.5t - 21t



Smooth or Padfoot drum, unblocked, minimum of 6 x 10mm looped chains

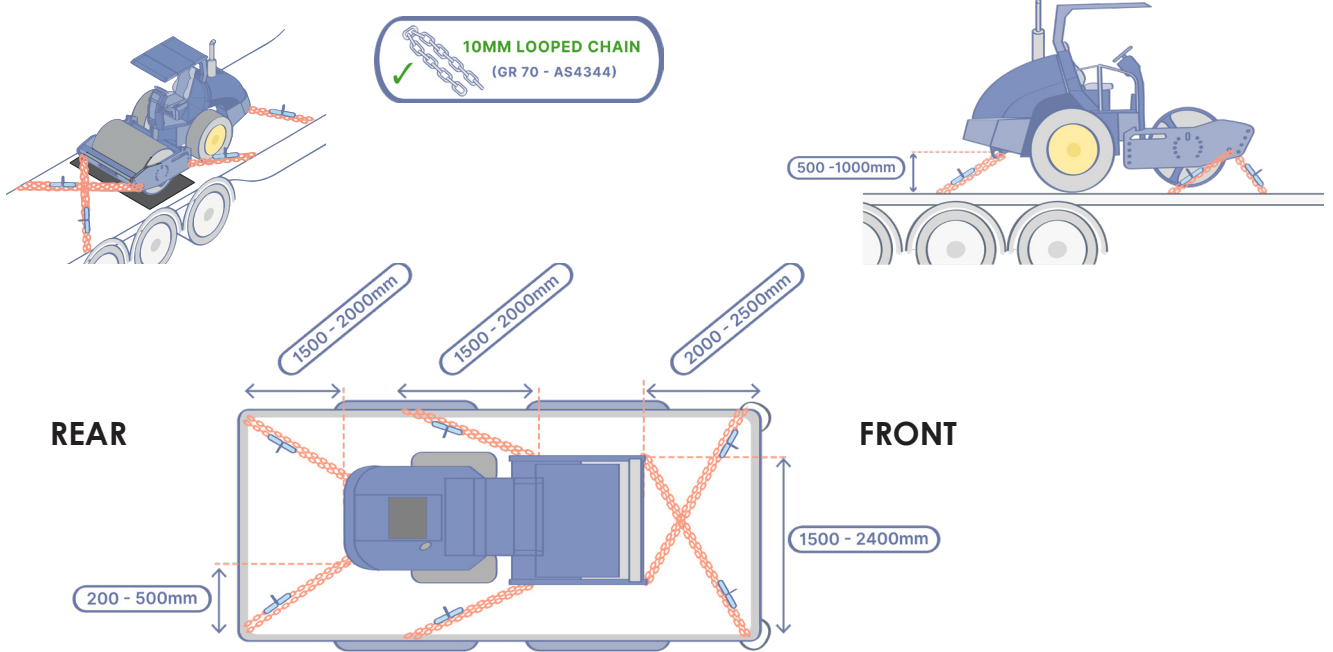

Pneumatic Roller, unblocked, minimum of 6 x 10mm looped chain

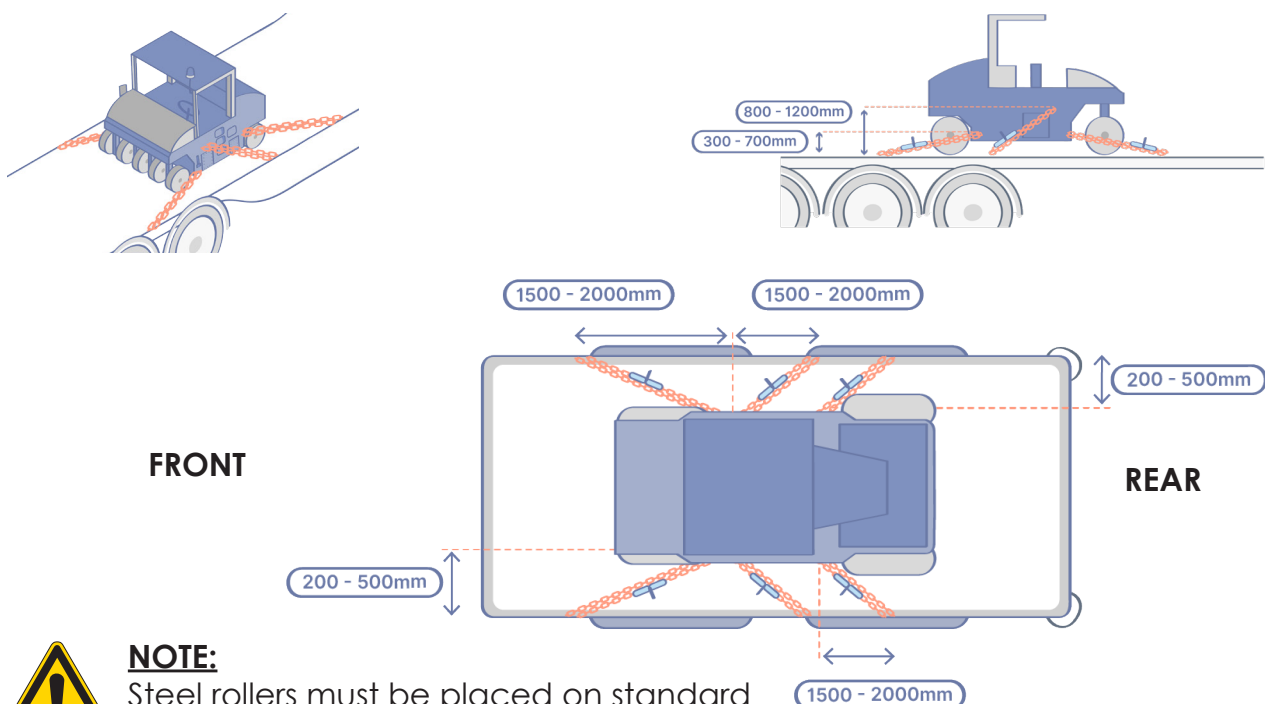

NOTE:
Steel rollers must be placed on standard industrial rubber no less than 10mm thick.

Accessories

General

- ✓ When securing accessories independent of plant ensure the correct size and quantities of chain are used for the given weight. (see table below)
- ✓ Ensure there are no loose items left on the deck. Loose items can be secured singularly or packed in a rated stillage or storage box.
- ⚠ Steel on steel contact reduces friction. Where possible use anti-slip, industrial rubber or timber to increase surface friction.

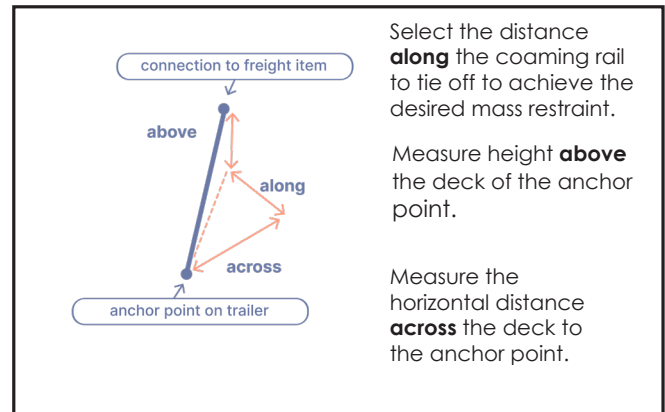
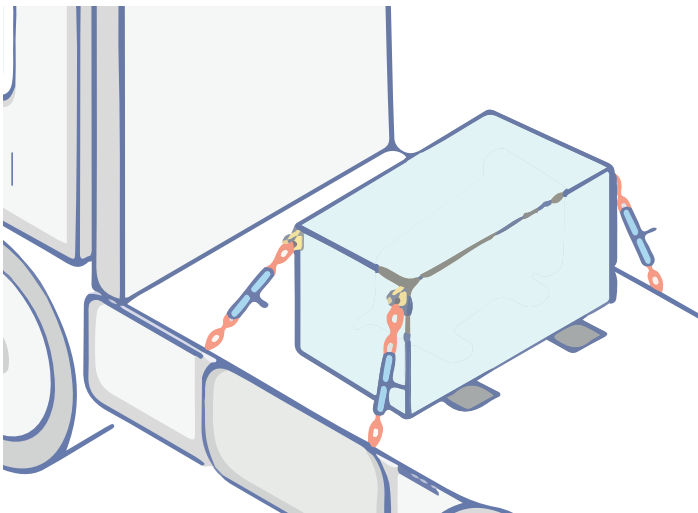

Engineered Maximum Permissible Restrained Mass

Direct Restraint Table - 4 lashings placed on timber or industrial rubber frictional coefficient 0.4

	Anchor Point Across Deck (mm)	Location Along Coaming Rail for Lashing (mm)	Mass per 4 × 50mm Webbing	Mass per 4 × 8mm Chain
 Height of Anchor Point (mm)	250 - 499	0 - 249	900 kg	3000 kg
		250 - 500	1500 kg	5000 kg
	300 - 599	0 - 249	617 kg	2000 kg
		250 - 500	1100 kg	3500 kg
Height of Anchor Point (mm)	250 - 499	0 - 249	1100 kg	3500 kg
		250 - 500	1500 kg	5000 kg
	599 - 1000	0 - 249	900 kg	3000 kg
		250 - 500	1300 kg	4000 kg